



Experiment No. 5 LEDs and Phototransistors, Digital Optical Communications

By: Prof. Gabriel M. Rebeiz
The University of Michigan
EECS Dept.
Ann Arbor, Michigan

1.0 Light Emitting Diodes:

Light emitting diodes (LED) are used extensively in displays, remote controls and sensor systems (intruder alarms, etc. ...). You may be surprised to know that any pn diode emits light when biased, but only the LEDs are optimized to generate a lot of light and to allow this light to escape from the semiconductor. The wavelength of the emitted light is proportional to the bandgap of the semiconductor (see EECS 320) and different materials are used to generate different light colors (Table 1).

Table 1: CHARACTERISTICS OF VISIBLE LIGHT-EMITTING DIODES (from M.G. Craford, "LEDs Challenge the Incandescents," *IEEE Circuits and Devices Magazine*, September, 1992).

Structure	Material	Bandgap type	Peak wavelength, nm (color)	Typical performance, lm/W
Homojunction	GaAsP	Direct	650 (red)	0.15
	GaP: Zn, O	Indirect	700 (red)	0.4
	GaAsP: N	Indirect	630 (red) 585 (yellow)	1
	GaP: N	Indirect	565 (yellow-green)	2.6
	GaP	Indirect	555 (green)	0.6
	SiC	Indirect	480 (blue)	0.04
	Single heterojunction	A1GaAs	Direct	650 (red)
Double heterojunction	A1GaAs	Direct	650 (red)	4
	A1GaP	Direct	620 (orange)	20
	A1InGaP	Direct	595 (amber)	20
	A1InGaP	Direct	570 (yellow-green)	6
	GaN	Direct	450 (blue)	0.6
Double heterojunction with transparent substrate	A1GaAs	Direct	650 (red)	8



A cross-section of an LED is shown in Figure 1. The small V-shape reflector behind the pn junction reflects the light emitted to the backside and therefore increases the forward light intensity. Also, a magnifying dome lens is placed in front of the diode to concentrate the emitted light in a narrow angle (typically 20-90°) from the boresight.

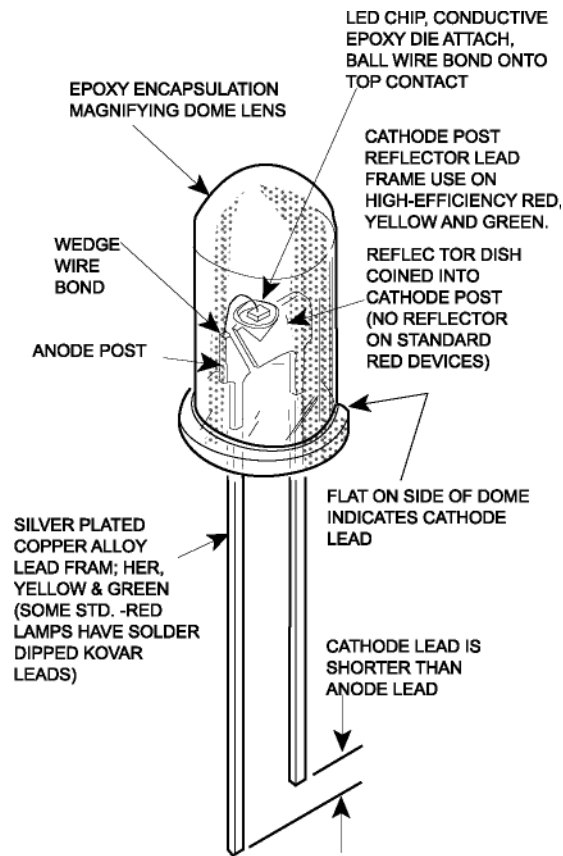

Figure 1: An LED and its domed lens structure. (Courtesy of Agilent Technologies).

One of the main most confusing notations in LED (and photometry in general) is the Lumens and Candlelight units. The basic unit of power in SI units is W (or mW). When you have radiation, the basic unit of power is W/m^2 , (or mW/cm^2) and specifies the power density of light (or electromagnetic radiation) produced at a certain distance from the source. This means that if an LED produces an on-axis power density of $0.1 mW/cm^2$ at a distance of 10 cm from its location, and there is a detector with a capture area of $0.2 cm^2$, then the detector will capture 0.02 mW of power (Fig. 2). This is easy and intuitive and all of the wireless/RF/microwave field relies on these units.

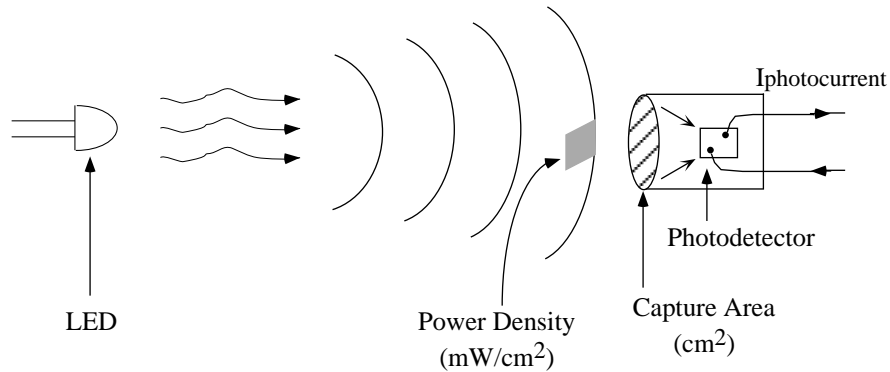

Figure 2: Schematic representation of power density and capture area.

However, life is not that easy when the human eye is involved since its response is very sensitive to the wavelength of light (Fig. 3a). The eye is most sensitive to 555 nm (greenish/yellow colors) and has about 20 times less sensitivity to the red or blue colors. So, if two LEDs, a green/yellow and a red one, are emitting the same amount of optical power in mW (or mW/cm²), then the green/yellow one will appear 20x brighter than the red one! Fig. 3 is called the CIE curve (Commission Internationale de L' Eclair), a French commission which has set this standard since more than 100 years.

So, rather than specifying an LED diode by the amount of optical power it produces in nice SI units such as mW (or mW/cm²), it is specified in *Lumens* or *millicandella (mcd)* and it is the unit of power as *perceived* by the eye! Look at the specifications of the Agilent 3316 LED (red) and the Agilent 3416 LED (yellow). They both have the same rating of a minimum mcd of 20 for a 10 mA of bias current. However, the red LED must be giving around 18x more optical power to be perceived as bright as the yellow LED. Since both LEDs have the same input power, the red LED is therefore 18x more efficient in converting its input power to optical power than the yellow LED!

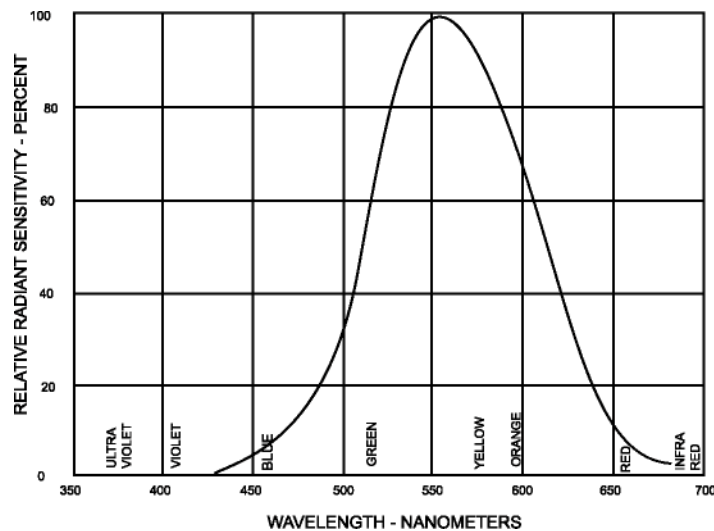

Figure 3a: The CIE curve. From *Optoelectronics*, Vaughn D. Martin, p. 12.



The Agilent 3316 LED (see attached data sheet):

This LED is made of a new heterostructure material, AlGaAs, and has a very high conversion efficiency (6-8%) between the input power and the emitted light intensity (optical power). Its peak wavelength is 635 nm (red) and its spectral line width (bandwidth of emitted light) is only 40 nm. This is the reason it appears as an intense red and not a mix between red and yellow. It delivers 60 mcd (millicandella) typical at 10 mA of forward current which is a strong light for such a small amount of current. The angle between the half-power point is 35° and therefore it is quite directive. It is a fast LED with a capacitance of only 11 pF and a response time of 90 ns, and therefore, can be modulated up to 5 MHz for AM or FM applications.

The Agilent 3316 output light intensity is linear with applied current as shown by the graph of the relative luminous intensity vs. dc current (Fig. 3b). Actually, the light generation inside an LED is very complex and does not follow an exponential law. For a dc current of 15 mA or above, it is possible to ac modulate the current by +/- 5 mA while keeping a linear response, and therefore resulting in low distortion modulation. Since the diode resistance is around 3 Ω ($r_d = nV_T / I_{DC}$, $n = 2$, $V_T = 26mV$ and $I_{DC} = 15mA$), this means that an LED can handle ±15 mV_{pk} (or 30 mV_{ppk} across rd) before any appreciable distortion. This is much larger than a regular PN-junction diode.

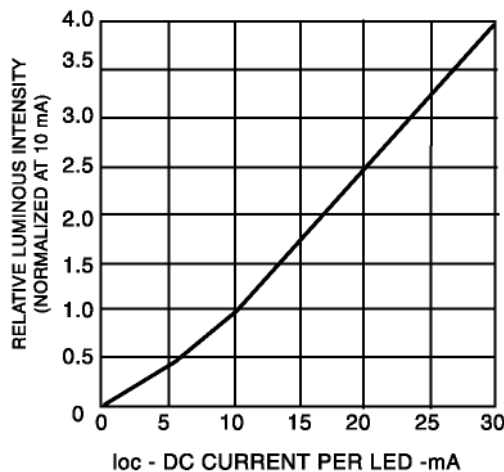

Figure 3b: Relative light intensity vs. DC input current for the Agilent 3316 LED.

2.0 Phototransistors:

A phototransistor is a transistor which is sensitive to the input light intensity. Basically, a small lens focuses the light to the base, and this light interacts with the semiconductor crystal and generates electrons (Fig. 4). The electrons are amplified by the transistor and appear as a current in the collector/emitter circuit. This current is called the “photocurrent”. A phototransistor has only two leads since the base is internally left open and is at the focus of a plastic lens.

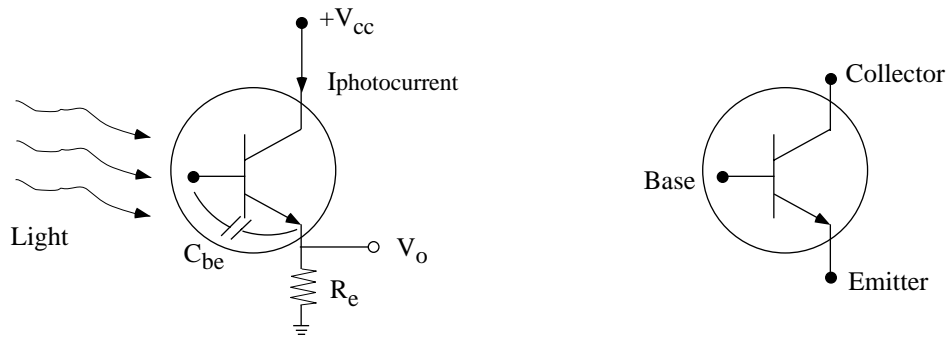

Figure 4: Schematic representation of a phototransistor. The base is generally not connected to the outside world.

The most important specification of a phototransistor is its spectral sensitivity. The Siemens BPX 81-3 is a silicon infrared phototransistor with a peak sensitivity at 860 nm (see attached data sheet). Its sensitivity drops to 60% of the peak value at 630 nm which is the wavelength of the Agilent 3316 LED. It is a directional phototransistor with a half-power sensitivity angle of 36° and therefore will not pick up a lot of noise from the neon lighting system on the ceiling. The photocurrent is specified in terms of Lumens (Lx) or in terms of incident power density (mW/cm^2), and is around 0.5 mA for an incident power density of 0.4 mW/cm^2 . Another important spec. is the “dark current”, and as its name indicates, it is the current which flows in the collector-emitter circuit for no input light. This is basically the internally generated noise of the phototransistor and is the limiting factor to the sensitivity of the photoreceiver system.

The speed of the phototransistor is limited by the base-to-emitter (C_{be}) capacitance and is specified in terms of the risetime of the device. Since C_{be} interacts mainly with the load resistor (R_e), the risetime is linearly dependent on R_e . For $R_e = 1\text{ K}\Omega$ the risetime is 6 μs , meaning that it can follow accurately a 100 KHz square-wave modulation. Phototransistors are not fast devices, and for a faster response, it is best to use a *photodiode*. A photodiode is basically the input section of the phototransistor (collector-to-base section) and does not have an emitter and therefore, does not suffer from the C_{be} effect. However, it produces 40-200x less photocurrent and therefore must be always followed by a differential amplifier. It is possible to build photodiode-based optical receivers with response times of sub-ns and these systems can detect GHz modulation speeds. These detectors are used in high-speed fiber optic systems.

3.0 Phototransistors and Square-Law Detection:

The photodetection process is inherently a non-linear process since the output current, I , is proportional to input power (or light intensity), P , and therefore to the input voltage squared.

$$I = kP \text{ proportional to } V^2$$

where k is the detector responsivity and has units of A/W . In the pre-lab, you will calculate k for the Siemens BPX 81-3 phototransistor.

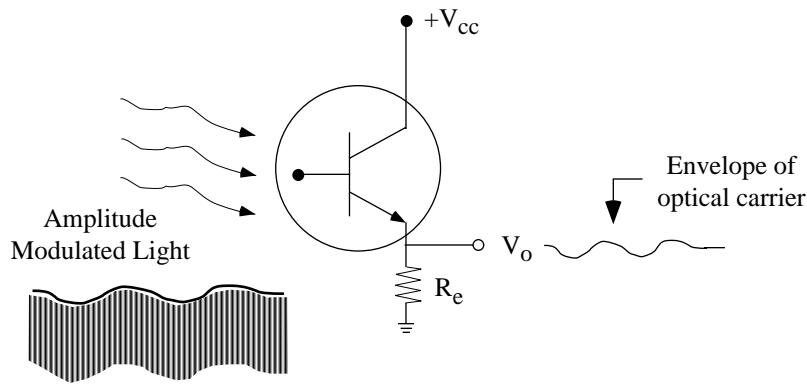

Figure 5: A phototransistor as an AM demodulator (envelope detector).

Since the detection process follows the square-law rule, it automatically demodulates any amplitude modulation on the optical carrier, just as the diode AM demodulator! The output voltage across R_e is therefore the demodulated signal (Fig. 5). If there is no amplitude modulation on the optical carrier, then the output voltage is a DC voltage and the phototransistor is acting as a square-law power meter (output dc voltage is proportional to the input power (or light intensity)).

With phototransistors, it is easy to explain the AM detection process using the time-constant approach. Remember that the phototransistor is a slow device and can only respond to changing signals of 1 MHz maximum. This means that it will surely not respond to the instantaneous optical signal (at 300 THz) and only to its envelope which is changing at KHz frequencies. Well, here it is, you have an *envelope detector* and therefore an AM detector!

4.0 Digital Optical Communications:

Although you will build a simple AM photonic link in Experiment #5 and use it to detect music in the lab with a bandwidth of 20 KHz, you should know that the backbone of the terrestrial telecommunication system is based on this simple idea. The modern digital telephone system works this way (Fig. 6):

1. Take several thousand users at the local switching office and digitize their voice (analog/digital converters) at a sampling rate of 6 KHz and an 8-bit resolution. This means that a single user generates a data stream of 48 Kbit/second (with no compression) and around 16 Kbit/second with compression.
2. Put several of these users on the same line. If you can transmit 1.0 Gbit/second, this means that every second you can put around 60,000 users on the same line! Actually, you need to put timing signals on the line and also the destination information. So, let us say that you can put 30,000 users on the line. The unit that does this is called a "multiplexer".
3. Modulate a laser diode (equivalent to the LED) digitally with the 1 Gbit/second information and put the output light of the laser diode in a fiber-optic cable. This is pure digital AM with "1"s and "0"s.
4. Run the fiber optic cable from NY to Chicago making sure to amplify the signal every 20 or so miles (since the light is attenuated a bit in the fiber-optic cable). The amplifiers are called "repeaters".



5. Use a photodiode (similar to the phototransistor) at the receive end and take the 1 Gbit/second information and divide it down into the 30,000 different users and the destination information. This is called a “demultiplexer”.
6. Send each of the 30,000 different users to their respective destinations. This is called a “switching network” or a “routing network”.
7. Just before it arrives to the final destination, decompress the signal and pass it by a digital to analog converter. You now have a connection between NY and Chicago!
8. And, imagine that this is all done is about one second after you finish dialing a number!

P.S: If you are sending internet information, then you do not need the A/D and D/A converters at both ends.

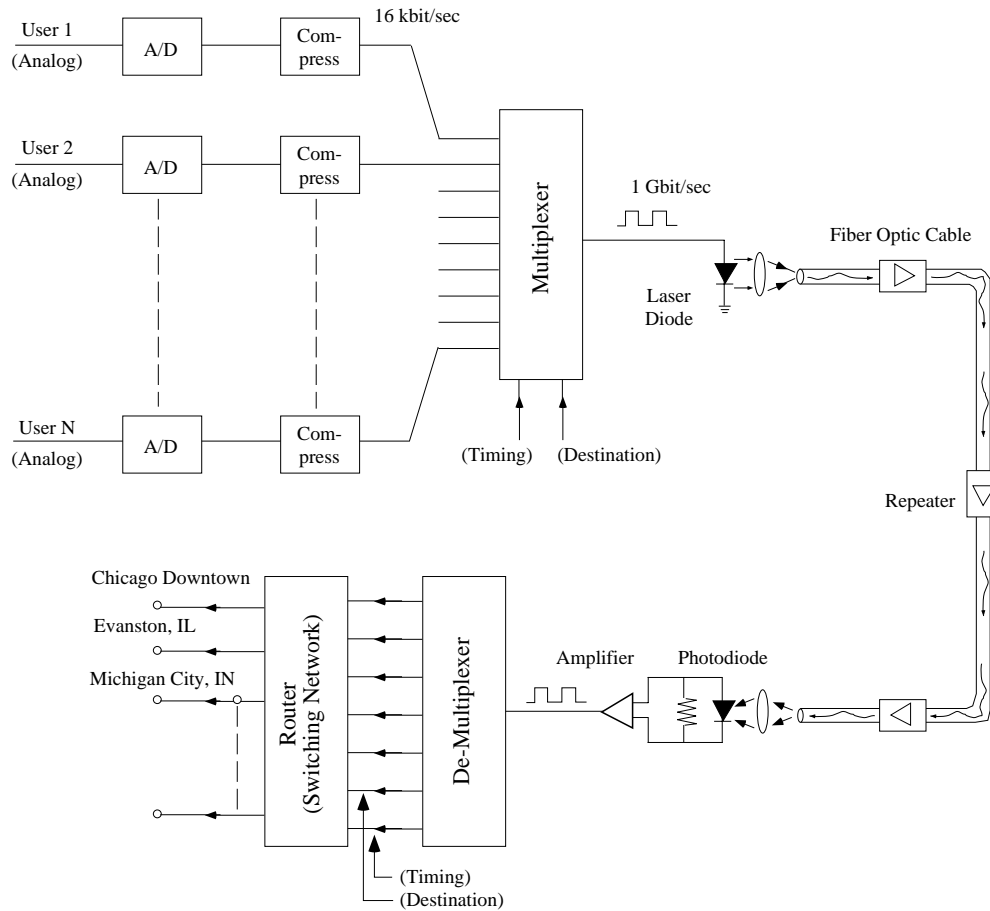

Figure 6: The optical digital telephone system.



Experiment No. 5 LEDs, Phototransistors and an AM Photonic Link.

Goal: To learn about light emitting diodes (LEDs) and phototransistors and to build a simple photonic link using amplitude modulation of an LED.

- Read this experiment and answer the pre-lab questions

Equipment:

- Agilent E3631A Triple output DC power supply
- Agilent 33120A Function Generator
- Agilent 34401A Multimeter
- Agilent 54645A Oscilloscope

1.0 The LED and Phototransistor

Connect the LED to the +9 V power supply using a 470 Ω resistor as shown below. Place a 100 μF capacitor (DC block) between the diode and the input signal source.

Connect the phototransistor to the +9 V supply using a 1 KΩ resistor at the emitter. Connect the emitter to the Agilent scope.

Align the LED and the phototransistor as shown below.

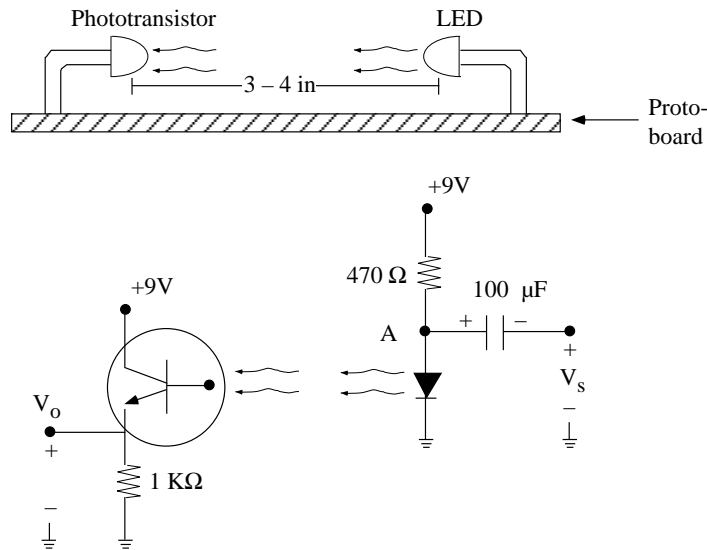

- Draw the LED (complete circuit and ac circuit) and the phototransistor circuit in your notebook.

Put the scope trigger to Line so as to trigger at the 60 Hz AC frequency. (You will notice that the output has a ripple at 120 Hz due to the light picked up from the fluorescent lighting system in the room.)

- On the scope, plot V_o (DC and AC) of the phototransistor with no input ac signal to the diode. From V_{oDC} (V_{avg} on the scope), calculate the DC photocurrent in the collector/emitter circuit of the phototransistor (this current is due to the light from the LED).



- c. Put a black tube cover over the phototransistor to reduce the pick-up 120 Hz noise. It should be possible to reduce it to less than 2 mV_{ppk}. Align the LED and the phototransistor so as to result in maximum signal (DC voltage).
- 2. Connect the LED to the Agilent function generator (sinewave, 1 KHz, 400 mV_{ppk}).
 - a. Measure the voltage (V_{avg} and V_{ppk}) across the LED at node A. You will find that V_A is much greater than 20 mV! However, only a small part of this voltage (V_A) appears across the LED junction since R_s ~ 15 Ω and r_d~3 Ω.

Equivalent AC Circuit of the LED:

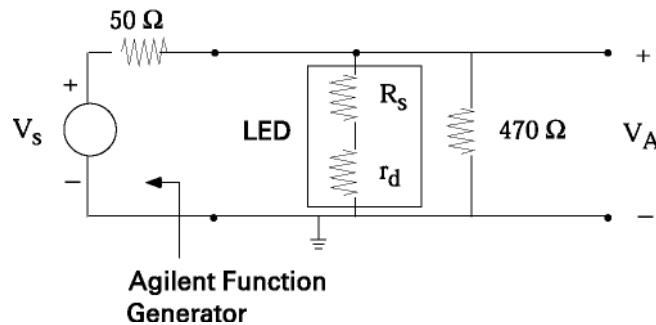

- b. Plot V_o (of the phototransistor) in time (V_{ppk} and V_{avg}) and frequency domains (f_o and several harmonics if possible). From the harmonic levels, is the LED operating in the linear region?
- 3. Repeat 2 but with V_s = 800 mV_{ppk} and 1.2 V_{ppk}. You will notice that the diode output intensity becomes non-linear as the voltage increases and that you pick up second and third harmonic components (at the phototransistor) due to the v² and v³ terms.
- 4. a. Set V_s = 600 mV_{ppk}, and using the knob, quickly sweep the frequency from 1 KHz to 40 KHz. In time or frequency domain, measure the phototransistor V_o and determine its 3-dB corner frequency (it should be around 25 KHz). Do not measure the frequency response.
 - b. Change the waveform to a square wave at 1 KHz and expand the phototransistor output on the scope. Measure the risetime of the square wave (should be around 10 μs) and check that the risetime value agrees with the 3-dB corner frequency measured above (check problem 3 in Pre Lab #1).
- 5. a. The phototransistor will deliver the same current independent of the load resistor R. Replace the 1 KΩ load resistor with a 5.1 KΩ resistor and measure V_o at 1 KHz (with V_s = 600 mV_{ppk}). Is it 5x larger than the measured voltage with a 1 KΩ load?
 - b. Do a quick frequency response and risetime measurement using the 5 KΩ load. What do you notice?
 - c. Put back the 1 KΩ resistor in the phototransistor circuit.



2.0 A Photonic AM link

First, we need to build an audio amplifier capable of driving the headphones which are supplied to you. This is very similar to Experiment #3 in the EECS 210 Lab.

1. a. Draw the LM380 amplifier circuit with the phototransistor in your notebook.
- b. Connect the LM 380 as shown below on a close part of the circuit. Make sure to put the 470 μF capacitor between V_{CC} (+9V) and ground, and the 4.7 μF bypass capacitor at pin #1. (I did not put them in and the LM 380 oscillated!). The 100 K Ω potentiometer/10 K Ω resistor at the input is for gain control.

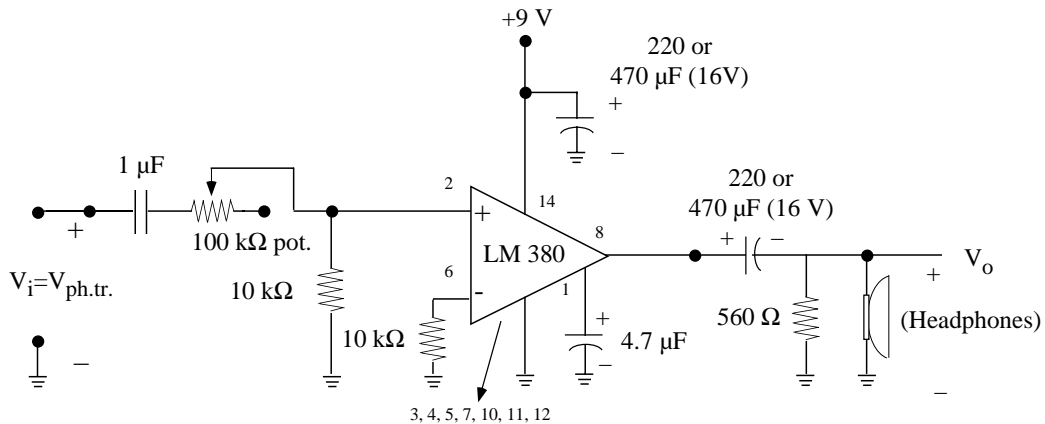

- c. Test the LM 380 audio amplifier at max. and min. gain settings (by putting a signal source at V_i and looking at V_o on the scope) at 1 KHz independently of the LED and phototransistor. After you are sure that it is working properly, connect the headphones to the output of the LM 380 audio amplifier.
2. a. Connect the LM 380 (via the 1 μF capacitor) to the phototransistor and modulate the LED with a 200 Hz to 10 KHz sinewave with $V_s = 400 \text{ mV}_{ppk}$ across the LED. Adjust the gain of the LM 380 to hear a clear undistorted tone. (You may also hear a hummmm and this is the 120 Hz pick up from the neon lights in the room.)
 - b. Set V_s to 600 Hz and increase its amplitude to 1.2 V_{ppk} . Listen to the distorted signal. You are now driving the diode into the non-linear region and are hearing the second and third harmonic components of the audio signal.
 - c. The TA will “shine” on you his/her transmitter which is connected to a tape player. Point your phototransistor in his direction and pick up the music. Write down which song/music did you hear.
 - d. If you have a portable tape/CD player, bring it to the lab and connect it to the LED via the headphone jack. Change the volume level on the tape/CD player and listen to the music (and distortion for loud volumes). You can display the music in time or frequency domain by looking at the output of the phototransistor or the LM 380 amplifier.



3.0 A Really Cool Boy (and Girl) Scout Experiment:

The 20 mcd Agilent 3316 LED is quite powerful around the campfire, and can transmit/receive over a couple hundred feet with inexpensive plastic lenses (the type that you used for bug-boxes when you were a kid). Notice that the experiment above only required 9 V and therefore, can be built using two 9 V batteries. The input to the LED could be a tape/CD player, or simply a small electric microphone which you can buy at Radio Shack. If you have small mirrors, you can deflect the LED beam around corners and trees and this is a cool experiment for kids of all ages.

Cost: The cost is minimal, less than \$12 for the whole system.

LED:	\$0.39
Phototransistor:	\$1.00
LM 380 or LM 386:	\$1.25
Resistors/Capacitors:	\$2.00
Microphone:	\$3.00
Headphone:	\$3.50
Plastic Lenses (2x):	\$0.50

(The LM 380 or the LM 386 are excellent audio amplifiers. The LM 380 has a fixed gain of 50 while the LM 386 has a variable gain from 20 to 200).

4.0 A Not-So-Cool Experiment

You can actually build the same thing but with an infrared LED and therefore, the light is not visible. Using this simple AM link, you can communicate with an accomplice on exams, a very shameful and dishonorable thing that I hope you will never do (or you may very well be expelled from UM). The dollar cost is still \$12 but it may cost you a lifetime!



Experiment No. 5 LEDs, Phototransistors and an AM Photonic Link.

Pre-Lab Assignment

- An LED is biased at 15 mA from a 9 V battery using a 470 Ω resistor. The DC voltage across the diode is 2 V. It is driven by a 50 Ω ac-source at 2 KHZ with $V_s = 400 \text{ mV}_{ppk}$. The measured ac voltage across the LED is 80 mVppk. (The measured total voltage across the diode is $V_o = 2 \text{ V} + V_{ac}$).

AC Circuit:

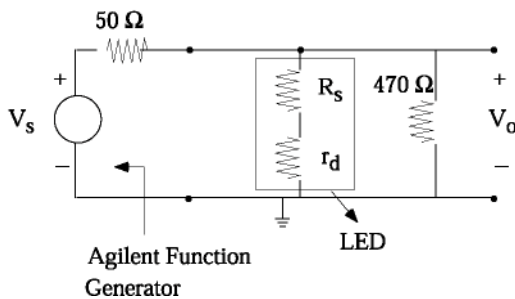

DC Circuit:

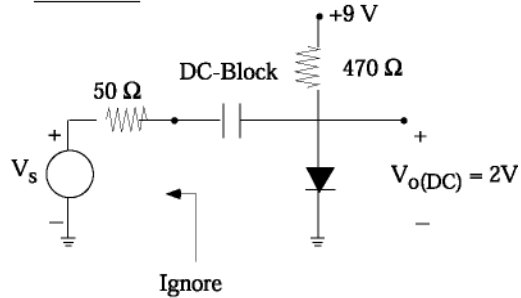

- Calculate the DC LED current and the ac diode resistance (r_d) for $n = 1.5$.
 - Calculate the total ac resistance of the LED ($R_s + r_d$) knowing V_s and $V_o(ac)$. What is R_s ?
 - Calculate the ac current, I_{ppk} , in the diode. Calculate the voltage across the diode junction across (r_d). Is the diode operating in the linear region?
- The speed of the Agilent 3316 LED is 90 ns (risetime). Knowing that the total ac (junction and series) resistance of the LED at a 15 mA bias current is around 18 Ω, calculate the effective ac capacitance of the diode? (You will see that it is much higher than the quoted capacitance of 11 pF and is due to the “diffusion capacitance” for the 15 mA bias current. You will study this in detail in EECS 320).
 - The Siemens BPX81-3 phototransistor response is given as $I_{photo} = 0.5 \text{ mA}$ for an incident power density of 0.4 mW/cm^2 at 830 nm (see data sheet).
 - Calculate the phototransistor responsivity, $k \text{ (A/W)}$, at 830 nm and 620 nm, knowing that the acceptance diameter is 1.6 mm.
 - The Siemens BPX81-3 phototransistor has a 6 μs risetime for a 1 KΩ load. Calculate the 3-dB corner frequency (see problem 3 of the Pre Lab #1). Calculate the effective C_{be} seen by R_e , the 1 KΩ emitter resistor. (You will see in EECS 311 that it is better to calculate the effective R_e seen by C_{be} and not the way we do it now).
 - Does the photocurrent (I_{photo}) depend on R_e ? Calculate the output voltage of the phototransistor (emitter voltage) for $R_e = 1 \text{ K}\Omega$ and $R_e = 20 \text{ K}\Omega$ with an incident power density of 0.1 mW/cm^2 (look at the data sheet. Do *not* use the acceptance diameter given above). Why would you choose a 1 KΩ load and not a 10 KΩ load?



Experiment No. 5 LEDs, Phototransistors and an AM Photonic Link.

Lab-Report Assignment

1.
 - a. From the measured ac voltage division ratio at the LED for $V_S=400$ mVppk, calculate the total ac resistance of the Agilent 3316 LED. For $n = 1.5$ and the DC bias current in the LED, calculate the junction (r_d) and series resistance (R_S) of the LED. Calculate the ac current and the ac voltage across the diode junction (across r_d).
 - b. Repeat (a) but for $V_S = 800$ mVppk and 1.2 Vppk. When does the diode start operating in the non-linear region?
 - c. Write the measured fundamental and harmonic levels of V_O (at the phototransistor) and calculate the total harmonic distortion generated by the LED for $V_S = 400$ mVppk, 800 mVppk and 1.2 Vppk. Correlate your answer with (b) above.
2. The measured output resistance of a portable tape-player is 16Ω . Calculate the maximum tape-player voltage (Vppk) so that the LED does not generate a lot of harmonics.
3.
 - a. Plot (approximately) the measured response of the phototransistor vs. frequency for $R_E = 1$ K Ω and $R_E = 5.1$ K Ω in dB/log f.
 - b. Make sure that the measured risetimes for $R_E = 1$ K Ω and $R_E = 5.1$ K Ω agree with the measured 3-dB corner frequency.
4. The TA is shining his/her LED on you and you cannot pick up the signal well with the phototransistor and the LM 380 amplifier. If there is one and one single component that you can change to increase the signal on the headphones, which component would you choose and what is the maximum value that you would choose? Explain your answer.